

BRTD-70 is a resistance temperature detector specifically designed for bearing temperature or other rotating shafts temperature. Copper Tip probe tip is inserted directly into drilled holes (such as bearing housing, machine components) or the process. With copper tip design small change in temperature can be detected quickly to avoid major damage to the bearing or shaft. TempoTech bearing RTD comes with electrically isolated tip to use in high voltage motors, electrically heated bearing. Electrically isolated helps to prevent any signal interference due to electric current.

Key Features

- Available in type Pt100, Pt1000, Cu10ohm, Ni120 ohm .
- Electrically isolated tip for electrically heated bearings.
- 20 time faster response than standard stainless steel tip.
- Available in Class B, Class A (IEC 60751 & ASTM E1137)
- Single and Duplex Sensor elements.
- Range -50°C to 260°C (-58°F to +500 °F)
- Cut to length style for easy installation on site.
- Sheath diameter is available 0.188, 0.215 and 0.250 Inch.
- High Vibration resistance and ultra-temperature option available

Technical Specification

Insulation Resistance : 1000 MG Ohms @ 500 vdc
Dielectric Strength: 1000 VAC at 60 Hz with 1 mA Maximum Leakage Current
Response Time : <5 Sec in circulating water @ 1ft/sec
Accuracy : As per IEC60751 (See tolerance chart)
Self Heating Error: < 0.30°F (0.17°C)
Time Constant : < 3 sec

RTD Wire Configuration

2 Wire: In 2 wire RTDs, one lead wire is connected to each wire of the RTD element. 2 Wire RTDs are an economical option for the applications where high accuracy is not required. Since there is no compensation wire, the accuracy of RTD can be affected if long lead wire is used.

3 Wire : 3 wire RTDs are the most common type of RTDs used in the industry. In 3 three-wire Rtd 1 wire is connected to the one side of the RTD element, and on the other side, 2 wires are connected to compensate for the resistance. With compensating wire, accuracy is very close to the element accuracy at the termination end.

4 wire: 4 wire RTDs are highly accurate. In 4 wire RTDs 2 wires are connected to each side of the RTD element. With additional wire on each side of the RTD element, the output at the termination is highly accurate. 4 wire RTDs are recommended where high accuracy and long lead wire is required.

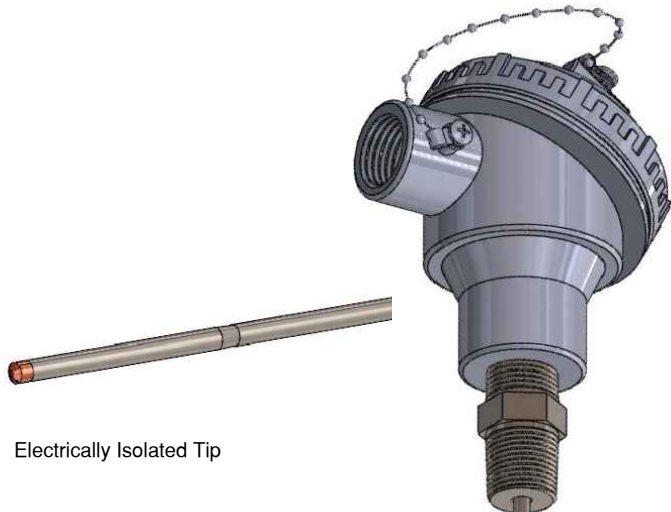
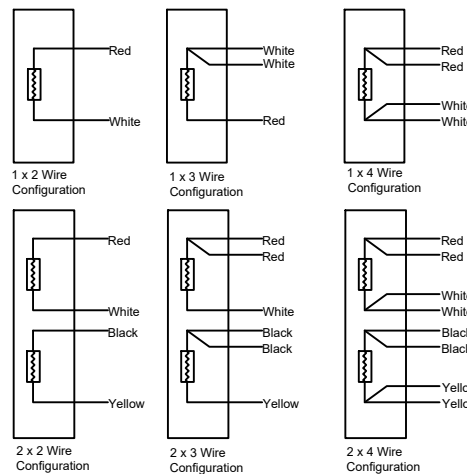

RTD Type Available					
Element Type	Pt100	Pt200	Pt1000	Ni120	Cu10
Wire Wound	X	X			X
Thin Film	X		X	X	
Alpha Value	IEC 0.00385 JIS 0.00391	IEC 0.00385 JIS 0.00391	IEC 0.00385	0.00672	0.004274

Our RTD class offerings and Tolerance as per IEC60751 (pt100)

Tolerance Class	Temperature Range °C		Tolerance Values Ω	Tolerance values °C
	Wire Wound	Thin Film		
AA	-50 TO +250	0 TO +150	±0.04	± (0.1 + 0.0017 t)
A	-100 TO +450	-30 TO +300	±0.06	± (0.15 + 0.002 t)
B	-196 TO +600	-50 TO +500	±0.12	± (0.3 + 0.005 t)
C	-196 TO +600	-50 TO +600	±0.23	± (0.6 + 0.01 t)

a | t | = modulus of temperature in °C without regard to sign

For 1/10 DIN B RTD is not standardize. The only accuracy defined is 1/10 of Class B accuracy at 0°C = 0.03°C

Tolerance Chart pt100 (IEC60751)

Temperature	Class B±	Class A±	Class AA± (1/3 DIN B)	Class 1/10 DIN B±
-50° C	0.55	0.25	0.19	0.060
0° C	0.30	0.15	0.10	0.030
100° C	0.80	0.35	0.27	0.070
200° C	1.30	0.55	0.44	0.120
250° C	1.55	0.65	0.53	0.160
300° C	1.80	0.75	0.61	0.220
350° C	2.05	0.85	0.70	-
400° C	2.30	0.95	0.78	-
450° C	2.55	1.05	0.87	-
500° C	2.80	1.15	0.95	-
550° C	3.05	1.25	1.04	-
600° C	3.30	1.35	1.12	-
650° C	3.55	1.45	1.21	-

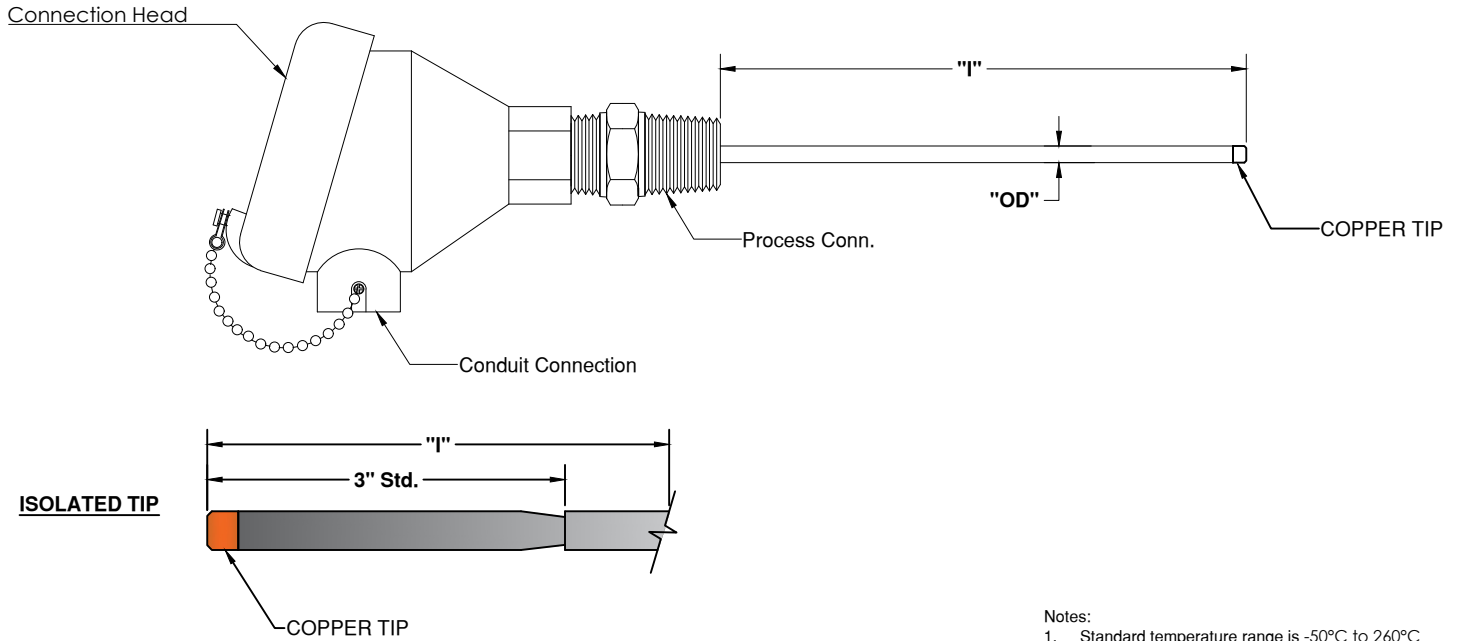

- Notes:
- Standard temperature range is -50°C to 260°C
 - Standard sheath material is SS316.

	1	2	3	4	5	6	7	8	9	10	11	12
BRTD70												

For Example- BRTD70-PT-A-S-04-3-6i-A-57-03-0-TB-0

1. RTD TYPE	
CODE	
PT	Pt100 Ohm, 0.00385, Coefficient
PTK	Pt1000 Ohm, 0.00385, Coefficient
CU	Cu 10 Ohm, 0.00427, Coefficient
NI	Ni120 Ohm, 0.00672 Curve Class B Only (Only Available in Low temp)

2. RTD ACCURACY	
CODE	
B	Class "B" (For Ni120)
A	Class "A" (For PT100)

3. SENSOR ELEMENT	
CODE	
S	Single
D	Dual

4. WIRE CONFIGURATION	
CODE	
02	2 wire (Red/White)
03	3 wire (Red/Red/White)
04	3 wire (Red/White/White) STD
06	6 wire (4Red/2Red) Dual Element
07	6 wire (Red/Red/White/Black/Black/Yellow) Only available with Dual Element

5. SHEATH OD		
CODE	IMPERIAL SIZE	METRIC SIZE
3	3/16"	4.76 mm
4	1/4"	6.35 mm
6	3/8"	9.5 mm
7	0.215"	5.46 mm

6. IMMERSION LENGTH (I)	
Immersion length - use "I" for inches and "M" for millimetre	

7. CONNECTION HEAD	
CODE	
A	Gen purpose Aluminum head IP68
EA	Economical Aluminum gen purpose head (non-rated)
S	SS general purpose
SX	SS Explosion proof
AX	Aluminum explosion proof (CSA, FM, ATEX, IECEx approved)
10	Aluminum connection head (CCOE approved)

8. PROCESS X CONDUIT CONN.	
CODE	
55	1/2" NPT X 1/2" NPT
57	1/2" NPT X 3/4" NPT

9. ELEMENT BUSHING STYLE	
CODE	
01	Fixed bushing
02	Spring loading bushing
03	Oil seal spring load bushing

10. ADJUSTABLE PROCESS FITTING	
CODE	
0	Not Required
2	1/8" MNPT
4	1/4" MNPT
6	3/8" MNPT

11. HEAD TERMINATION	
CODE	
OO	Blank Head Ready to Install Transmitter
TB	Ceramic Terminal Block
TRM	Standard 4-20 mA Transmitter
TRM-H	Standard 4-20 mA Transmitter w/ Hart

12. TIP STYLE	
CODE	
0	Standard Tip
INS	Isolated Tip